

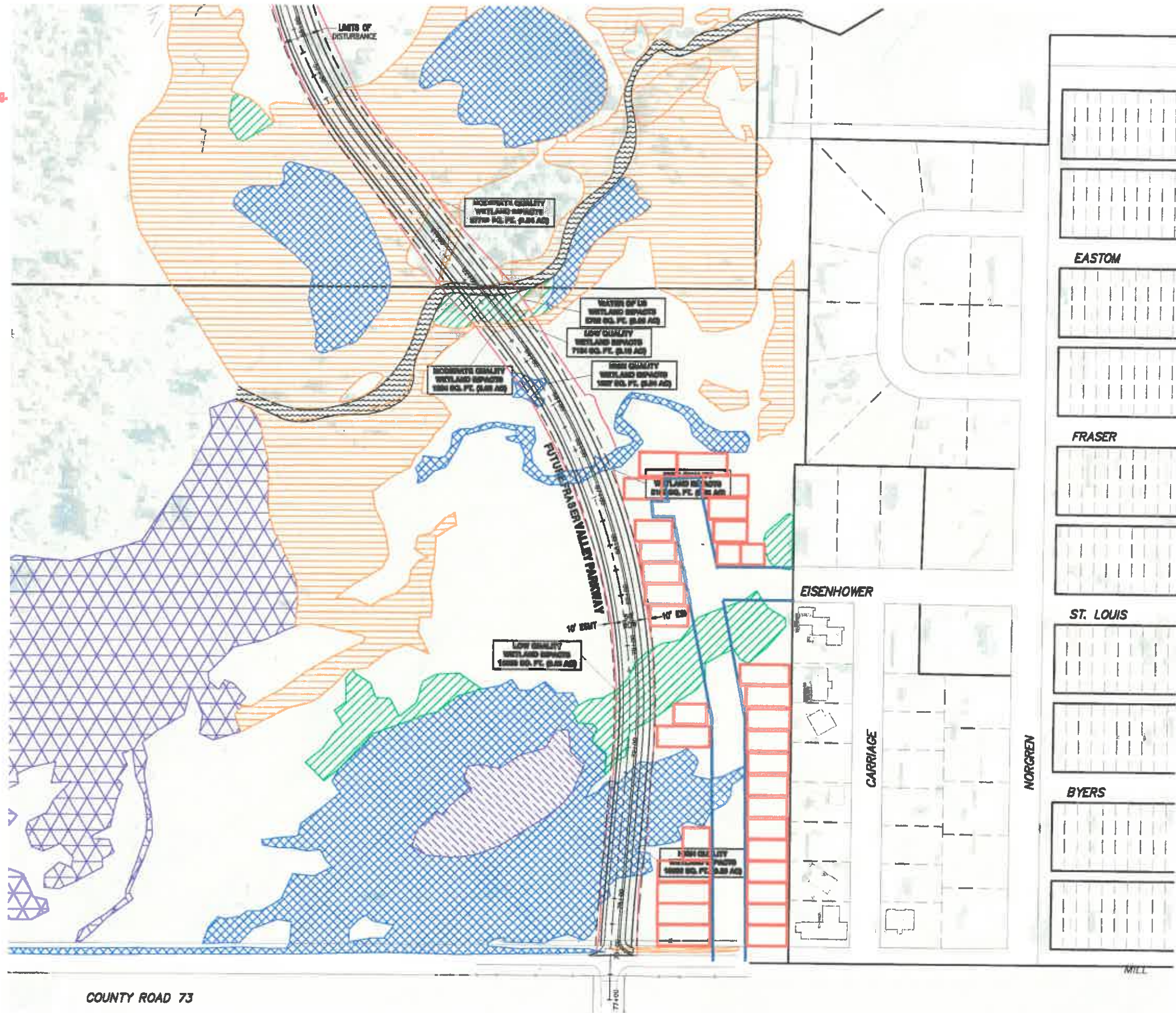

Know what's below.
Call before you dig.

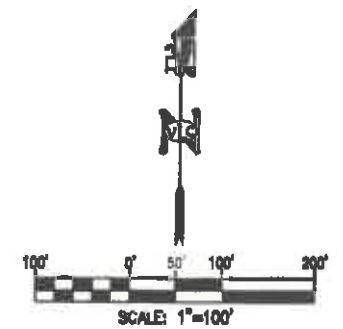

COUNTY ROAD 73



LEGEND:

- LOW QUALITY WETLANDS
- MODERATE QUALITY WETLANDS
- HIGH QUALITY WETLANDS
- MODERATE TO HIGH QUALITY WETLANDS
- FEN WETLANDS

NOTE:

1. SEE FRASER VALLEY PARKWAY ROADWAY PLAN AND PROFILES PREPARED BY VISION LAND CONSULTANTS, INC. FOR ADDITIONAL INFORMATION.

33 x 50' SFR lots

DATE	02/10/20
NO.	
CHECKED BY	TC
BY	
REVISION	
JOB NO.	2310.00

INFORMATION SHOWN IS SUBJECT TO CHANGE. NOT FOR CONSTRUCTION.

ONE SOURCE CONSTRUCTION SERVICES
ONE WEST ASHLEY DRIVE, SUITE 100
COLORADO SPRINGS, CO 80901
P: 719-575-1100
F: 719-575-1101
WWW.CONSOURCECONSTRUCTION.COM



FRASER VALLEY PARKWAY
WETLANDS IMPACT AREAS EXHIBIT
FRASER, COLORADO

SHEET
EX-1

\\img] [P: \2310.00-Fraser Valley\Documents\OneSource\2310-FVP-WET_IMPACTS.dwg] [Apr 01, 2009 - 8:15am]